

FRALOCK®

A Division of Lockwood Industries Inc

CIRLEX® Technical Data Sheet

Product Description

CIRLEX® has been developed to provide industry with a wider variety of thick polyimides to work with and pricing reflective of current and future market needs.

CIRLEX® has the same excellent balance of physical, chemical, and electrical properties over a wide temperature range as offered by all Kapton® films.

CIRLEX® is offered in thicknesses from 0.006" (0.15mm) to 0.125" (3.175mm). Thicker constructions are available.

CIRLEX® can be modified by laser cutting, drilling, machining, stamping, shearing and chemical etching to very exact tolerances.

CIRLEX® is offered with a wide variety of laminated foils, either on the surface or imbedded, utilizing all-polyimide adhesiveless technology. Special applications are always welcome.

Applications

- PCB stencils
- Loudspeaker components
- Metal clad, thick polyimide materials (>0.008" thick)
- High-density electronic interconnects
- High-temperature mechanical seals

Packaging

CIRLEX® is packaged in "lay-flat" containers with protective interleaving. Several thicknesses may be shipped in each box to best utilize space or shipped as required by the customer. Customers are responsible for shipping cost unless other arrangements are made.

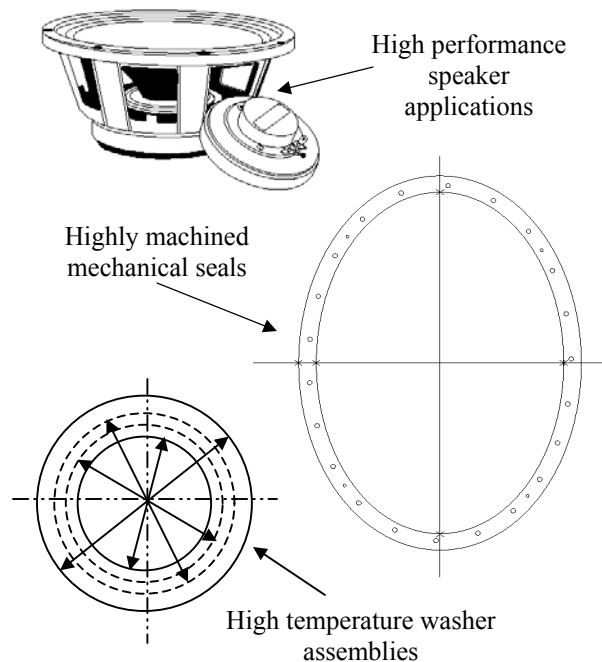

Contact Information – United States

Fralock, Main Office
21054 Osborne Street
Canoga Park, CA 91304
Phone 800.372.5625
Phone 2 – 818.709.1288
Fax 818.709.1736

Fralock, San Carlos
120 Industrial Road
San Carlos, CA 94070
Phone 650.966.1500
Fax 650.966.1861

Ordering Information:

Call Fralock at 1.800.372.5625
or contact Fralock on the web:
<http://www.fralock.com>
<http://www.cirlex.com>
MSDS available upon request

FRALOCK®

A Division of Lockwood Industries Inc

CIRLEX® Technical Data Sheet

Typical Properties of CIRLEX® at 23 °C (73 °F) and at 200 °C (392 °F)

Gauge	Cirlex® 900 CL	Cirlex® 1200 CL	Cirlex® 1500 CL	Cirlex® 3000 CL	Cirlex® 5000 CL
Thickness	0.009" (0.23mm)	0.012" (0.31mm)	0.015" (0.38mm)	0.030" (0.76mm)	0.050" (1.27mm)
Yield Point @ 3% Elong. (PSI)					
23 °C	6112	6500	7836	7097	6113
200 °C	5490	EL	EL	EL	EL
Stress @ 5% Elong. (PSI)					
23 °C	10360	10800	11230	10370	9413
200 °C	8339	EL	EL	EL	EL
Tensile (PSI)					
23 °C	32490	34000	35000	33300	31800
200 °C	32490	EL	EL	EL	EL
Elongation (%)					
23 °C	65	64	63	57	56
200 °C	85	EL	EL	EL	EL
Modulus (KPSI)					
23 °C	330	332	334	274	264
200 °C	239	EL	EL	EL	EL
Density (G/cc or G/ml)	1.42	1.42	1.42	1.42	1.42
Specific Heat (J/g K)	1.09	1.09	1.09	1.09	1.09
CTE (ppm/°C)	20 ppm	20 ppm	20 ppm	20 ppm	20 ppm
Tg (°C)	~351°C	~351°C	~351°C	~351°C	~351°C
Dimensional Stability 250 °C					
Machine Direction	0.13	0.09	0.07	0.27	0.20
Transverse Direction	0.07	0.07	0.07	0.27	0.40
Dimensional Stability 400 °C					
Machine Direction	0.33	0.33	0.33	0.13	0.00
Transverse Direction	0.40	0.40	0.40	0.40	0.20
Dielectric Strength					
V/mil	2790	2000	1940	1270	Arc Over
Dielectric Constant KHz					
25 °C	3.45	3.55	3.58	3.74	3.72
Dissipation Factor	0.0021	0.002	0.0018	0.0023	0.0026
Moisture Absorption					
% Max.	4.0	4.0	4.0	4.0	4.0
Thermal Conductivity					
W/m K	0.17	0.17	0.17	0.17	0.17
UL Rating					
UL File # - E39505	UL 94V0	UL 94V0	UL 94V0	UL 94V0	UL 94V0

* EL (Material exceed test limits of equipment)

The information given herein is based on data believed to be reliable, but Fralock makes no warranties express or implied as to its accuracy and assumes no liability arising out of its use by others. This publication is not to be taken as a license to operate under, or recommendation to infringe, any patent.